

INSTRUCTION BOOKLET

**READ AND SAVE
THESE INSTRUCTIONS**

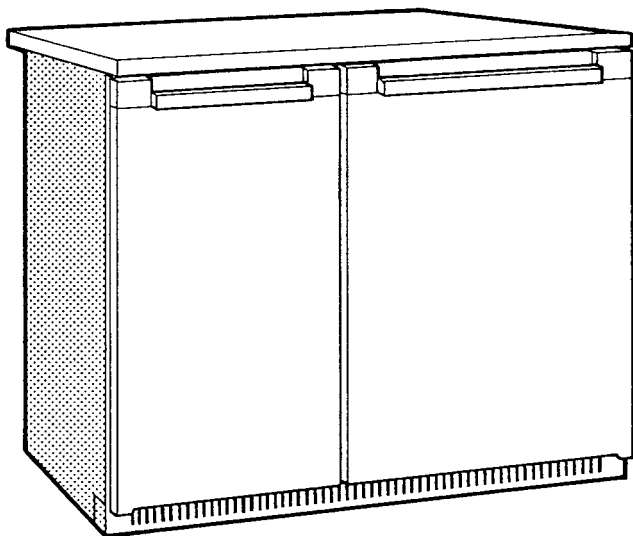

**FRIDGE-FREEZER
SIDE-BY-SIDE
DF 45/30 SS**

ZANUSSI

INDEX

Page	4	Installation
Page	4	Positioning
Page	4	Levelling
Page	5	Electrical connections
Page	5	Cleaning the inside
Page	6	Aligning the work top
Page	6	Fitting under kitchen work surfaces
Page	7	Use
Page	8	Temperature guide
Page	8	Starting the appliance
Page	8	Setting the temperature
Page	8	Everyday use of the temperature guide
Page	8	What to do if the temperature guide shows to warm
Page	10	Refrigeration compartment
Page	11	Helpful hygiene tips
Page	12	Freezer compartment
Page	12	Some useful hints for freezing
Page	13	Storing ready-frozen foods
Page	13	Thawing
Page	13	Making ice cubes
Page	14	Defrosting
Page	15	Maintenance
Page	15	Internal cleaning
Page	15	External cleaning
Page	15	Periods of non-use
Page	15	Replacing the bulb
Page	15	Temperature guide
Page	16	What to do if the appliance does not work
Page	22	ZANUSSI guarantee conditions
Page	23	ZANUSSI 5 year cover

TECHNICAL DATA

Height	85-82 cms
Width	90 cms
Depth	60 cms
Capacity:	
Fridge	4.5 cu. ft.
Freezer	2.9 cu. ft.
Fast freeze capacity	4 kg per 24 hrs
Power consumption	1.5 kWh

REFRIGERATION WARNINGS

It is most important that this instruction book should be retained with the appliance for future reference. Should the appliance be sold or transferred to another owner, or should you move house and leave the appliance, always ensure that the book is supplied with the appliance in order that the new owner can be acquainted with the functioning of the appliance and the relevant warnings.

These warnings are provided in the interest of safety. You must read them carefully before installing or using the appliance.

-
- ▲ This appliance is designed to be operated by adults. Children should not be allowed to tamper with the controls or play with the product.
 - ▲ Any electrical work required to install this appliance should be carried out by a qualified electrician or competent person.
 - ▲ This product should be serviced by an authorized Zanussi Service Force Centre, and only genuine Zanussi spare parts should be used.
 - ▲ It is dangerous to alter the specifications or modify this product in any way.
 - ▲ Care must be taken to ensure that the appliance does not stand on the electrical supply cable.
 - ▲ Zanussi domestic refrigerators and fridge/freezers are designed to be used specifically for the storage of edible foodstuffs only.
 - ▲ Frozen food must not be re-frozen once it has been thawed out.
 - ▲ Manufacturers' storage recommendations should be strictly adhered to. Refer to relevant instructions.
 - ▲ There are working parts in this product which heat up. Always ensure that there is adequate ventilation as a failure to do this will result in component failure and possible food loss. See installation instructions.
 - ▲ Parts which heat up should not be exposed. Wherever possible the back of the product should be against a wall.
 - ▲ Before any cleaning or maintenance work is carried out, be sure to switch off the appliance and unplug.
 - ▲ The inner lining of the appliance consists of channels through which the refrigerant passes. If this should be punctured this would damage the appliance beyond repair and cause food loss. DO NOT USE SHARP INSTRUMENTS to scrape off frost or ice. Frost may be removed by using the scraper provided. Under no circumstances should solid ice be forced off the liner. Solid ice should be allowed to thaw when defrosting the appliance. See defrost instructions.
 - ▲ The appliance should be left for 2 hours after installation before it is turned on in order to allow the refrigerant to settle.
 - ▲ Do not place carbonated or fizzy drinks in the freezer as it creates pressure on the container, which may cause it to explode, resulting in damage to the appliance.
 - ▲ This appliance is heavy. Care should be taken when moving it.
 - ▲ Ice lollies can cause frost burns if consumed straight from the freezer.
 - ▲ Under no circumstances should you attempt to repair the appliance yourself. Repairs carried out by inexperienced persons may cause injury or more serious malfunctioning. Refer to your local Zanussi Service Force Centre, and always insist on genuine Zanussi spare parts.
 - ▲ Do not remove temperature guide instructions from the interior of appliance.
-

INSTALLATION

If this new appliance, provided with a magnetic door seal, is replacing one which has a sprung door closing device or a locking device, you are advised to ensure that these devices are made inoperable so that the door can no longer be retained in a sprung or locked closed position before discarding the appliance.

This is to avoid the possibility of children accidentally shutting themselves in the appliance and thus endangering their lives.

1

POSITIONING

Position the appliance well away from sources of heat (radiators, stoves, cooking appliances, direct sunlight etc.).

The best performance is obtained with a room temperature of between $+10^{\circ}\text{C}$ and $+32^{\circ}\text{C}$.

The appliance can be fitted next to other kitchen units as long as air can circulate freely (see figure).

It is important that the bottom grill is not obstructed as the air must circulate freely through this grill.

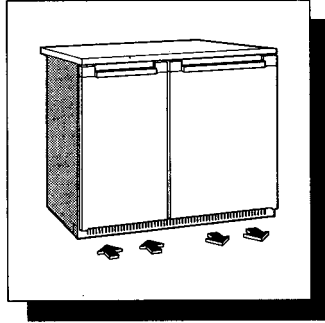

2

LEVELLING

The appliance is provided with two levelling feet located at the front, and two rear castors for easy movement.

The refrigerator should be levelled accurately, adjusting the feet as shown in the figure so that it is tilted slightly backwards to facilitate closure of the doors.

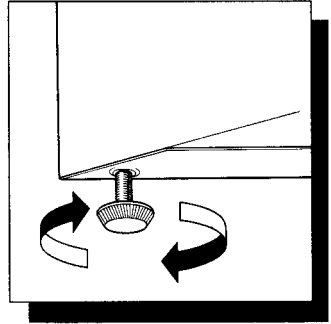

3**ELECTRICAL CONNECTIONS**

This appliance must be earthed.

The manufacturer declines any liability should this safety measure not be observed.

If the plug that is fitted to your appliance is not suitable for your socket outlet, it must be cut off and the appropriate plug fitted.

The cut off plug should be disposed of to prevent the hazard of electric shocks in case it should be plugged into a 13 Amp socket in another part of your home.

IMPORTANT

The wires in this mains lead are coloured in accordance with the following code:

GREEN AND YELLOW - EARTH
BLUE - NEUTRAL
BROWN - LIVE

If you fit your own plug the colours of the wires in the mains lead of your appliance may not correspond with the markings identifying the terminals in your plug, this is what you have to do:

Connect the green and yellow (earth) wire to the terminal in the plug which is marked with the letter (E) or the earth symbol \perp or coloured green, or coloured green and yellow.

Connect the blue (neutral) wire to the terminal in the plug which is marked with the letter (N) or coloured black.

Connect the brown (live) wire to the terminal in the plug with the letter (L) or coloured red.

The plug moulded onto the cord incorporates a fuse. For replacement, use a 13 Amp BS1362 fuse. Only ASTA approved fuses should be used.

The fuse cover/carrier colour is the one shown by the coloured insert at the base of the plug.

The plug must not be used if the fuse cover/carrier is lost. A replacement cover/carrier must be obtained from Zanussi Service agents whose addresses are listed on the attached Zanussi Service Agents Nationwide.

This appliance complies with E.E.C. directive no. 87/308 of 2.6.87 relative to radio interference suppression.

4**CLEANING THE INSIDE**

Wash the inside of the appliance with lukewarm water and a little bicarbonate of soda (1 teaspoonful to 1.2 litre/2 pints of water). Do not use soap or detergent as the smell might linger. Dry thoroughly.

INSTALLATION

5

ALIGNING THE FRIDGE-FREEZER TOP WITH THE OTHER KITCHEN UNITS

The appliance comes with the top aligned with the door. To change the alignment, follow the instructions below:

remove the screws A fixing the rear brackets to the top; move the top and, having selected the new position, refit the screws.

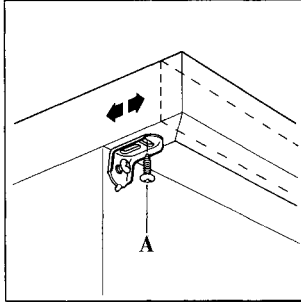

6

FITTING THE APPLIANCE UNDER THE KITCHEN WORK SURFACES

This appliance can also be fitted under your existing kitchen unit tops following the instructions below:

remove the screws A fixing the rear brackets C to the top, detach the top from the catches B and remove.

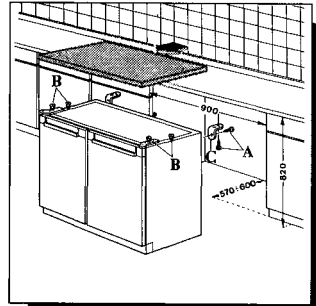

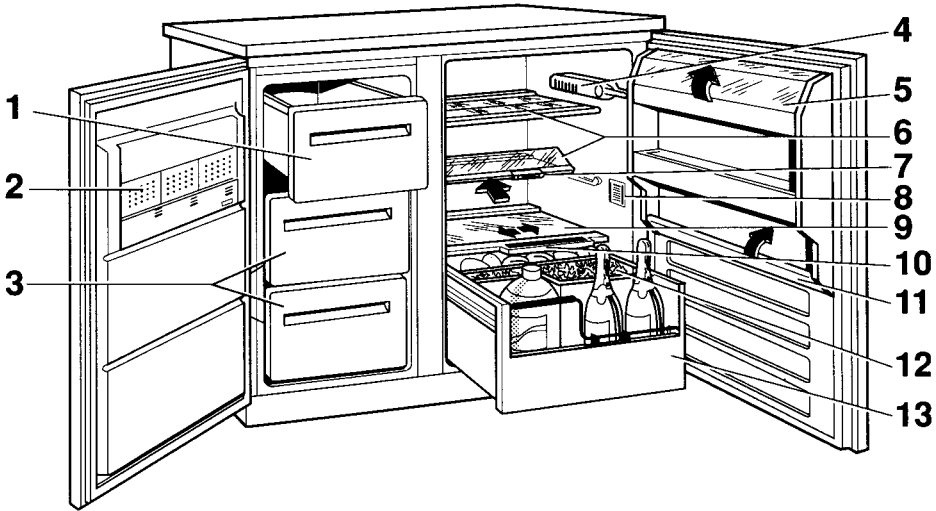

1. Fast freezing compartment
2. Food charts, freezing calendar
3. Frozen and deep-frozen products
4. Thermostat, ambient temperature switch, light
5. Butter and cheese
6. Cooked foods, cold meats, foods used every day. For best use of the space, the front shelves can be folded back onto the rear shelves
7. Temperature guide
8. Temperature guide instructions
9. Meat, fish
10. Freshness control
11. Small items such as tubes or cubes of flavour concentrates
12. Fruit and vegetables
13. Bottles

The model you have purchased has a temperature guide fitted to a shelf in the fridge compartment.

This guide is designed to show whether the fridge is operating at the safe storage temperature for all food types.

TEMPERATURE GUIDE

The guide consists of a temperature sensitive strip sealed in the shelf trim.

When the fridge is operating at the safe temperature to store food the guide will appear black. If the temperature rises above this level the guide will show the words **TOO WARM**.

The shelf with temperature guide must be placed in the fridge according to the instructions located on the fridge wall and always ensure the guide is at the front.

When cleaning the shelf take care not to immerse the guide in water and wipe any spills from the holder quickly.

IMPORTANT: The guide is only suitable for use in the model supplied and accurate temperature guidance cannot be guaranteed if transferred to other appliances. The guide will not operate in the freezer compartment.

STARTING THE APPLIANCE

Plug in the appliance and switch on the mains supply.

Open the fridge door and position the thermostat control knob between 3 and 4. Check the shelf with the temperature guide is positioned correctly (as described above). Close the fridge door and leave the appliance overnight to allow the temperature to reach a safe level.

If after waiting overnight the temperature guide still shows **TOO WARM**, adjust the thermostat to a higher number, close the door and allow to stand for 2-3 hours.

A higher thermostat setting may be required to keep the fridge temperature at the safe storage level during warm weather.

SETTING THE TEMPERATURE

The temperature inside the **refrigerator** and **freezer** is regulated by a single thermostat with 6 functional positions and one «stop» (●) position.

Position 1 = minimum cold
Position 6 = maximum cold

Turn the thermostat dial to the required position; **the intermediate position is usually the most suitable.**

The thermostat setting can vary as the temperature inside the refrigeration compartment depends on the following factors:

- room temperature
- how often the door is opened
- how much food is stored
- position of the appliance

EVERYDAY USE OF THE TEMPERATURE GUIDE

During everyday use a fridge door is opened many times and as a result temperature fluctuations may occur. A Zanussi fridge is designed to cope with any changes in temperature but under certain conditions the temperature guide in the appliance may show **TOO WARM**.

WHAT TO IF THE TEMPERATURE GUIDE SHOWS TOO WARM

The temperature guide may show **TOO WARM** if:

1. The fridge is switched off.
Action: Start the appliance in accordance with the instructions on page 8.
2. The fridge door has recently been opened or is left open for more than approximately one minute.
Action: As mentioned before the temperature guide is sensitive to changes in fridge temperature and opening the fridge door may cause the guide to show **TOO WARM**.
This should not cause concern as such fluctuations in temperature do not generally affect the safe storage of food. Leave the fridge door closed for as long as possible so the temperature returns to a safe level, the guide should then appear black.
3. The fridge has been loaded with fresh shopping.

Action: When fresh shopping or additional quantities of food are placed in the fridge, the temperature may rise and cause the guide to show TOO WARM. Do not adjust the thermostat as the time taken for the guide to appear black will depend on the quantity of food introduced and the temperature.

4. The fridge temperature is above the recommended maximum for the safe storage of all food types.

Action: To lower the fridge temperature adjust the thermostat in accordance with the instructions on page 8. Leave the fridge overnight before checking the guide again.

IMPORTANT

If the fridge is not defrosting correctly, it is possible that because a very low temperature has been selected, the motor is working continuously, which prevents the defrost cycle from operating.

To ensure correct defrosting, a lower number should be selected on the thermostat and you should notice that the motor cuts out from time to time, which is correct.

If you wish to return to a lower temperature, turn the thermostat to a higher number, however you should turn the setting lower occasionally to allow automatic defrosting.

To ensure that the appliance is working efficiently when the room temperature drops below 16 degrees centigrade, a switch is located underneath the thermostat housing and you will need to look underneath to check the correct setting.

The operating position is where the switch is depressed to letter «D».

You should ensure that this switch is used correctly, and it is most likely that it will need to be in position «D» throughout the winter to allow for the low overnight temperatures. No damage can be caused by leaving the switch in this position for a period of time.

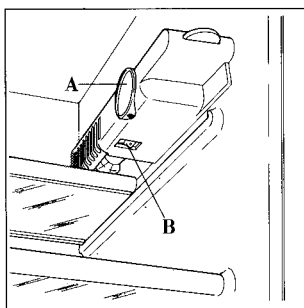

A = Thermostat dial
B = N/D Switch

REFRIGERATION COMPARTMENT

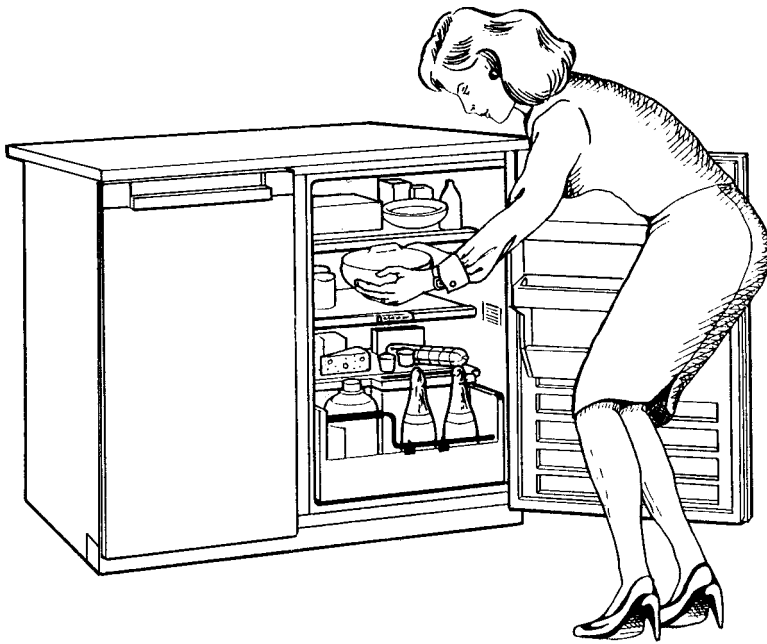

REFRIGERATOR COMPARTMENT

The coldest area of the refrigerator is the lower part, above the fruit and vegetable drawer.

For the best performance from your refrigerator, always follow these rules:

- make sure the appliance is installed correctly
- regularly check the temperature guide
- never put hot drinks or food into the refrigerator, leave them to cool to room temperature first
- cover food, especially if strong smelling
- space out the food so that the air can circulate freely around it
- don't block the gap between the front part of the shelves and the back.

REFRIGERATION COMPARTMENT

FRESHNESS CONTROL

The fruit and vegetable compartment can accumulate moisture, depending on the type of food stored. To regulate the build-up of damp air in this compartment there is a grill which can be adjusted. For salads and leafy vegetables, a high moisture content will ensure that they retain their freshness but root vegetables such as turnips require a less moist atmosphere. The adjuster allows you to select the best conditions for your food, the atmosphere will be dryer the more the grill is opened.

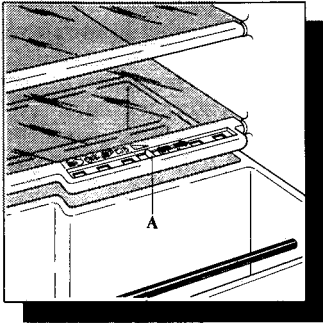

HELPFUL HYGIENE TIPS

- Always wash your hands with soapy water and dry them with a clean towel before handling food.
 - Keep work surfaces clean and avoid cross contamination by not using the same work surface for raw and cooked food without washing it thoroughly in between.
 - Use clean kitchen roll whenever possible for cleaning up food. If you use a dishcloth be sure to boil it frequently.
 - Regularly remove suspect food from your refrigerator and clean the interior with a solution of bicarbonate of soda in warm water (1tbs to 1 litre of water). Never allow spills to dry and harden.
 - Regularly check the refrigerator door seal to ensure that it is clean and free from bits and pieces.
 - Make sure that food is used before its «best before» date.
 - Cool food as quickly as possible but don't place in refrigerator or freezer until cool. (Leave food in a place as cool as possible in order that it can be placed in the refrigerator or freezer without delay).
- Do not store food uncovered.
 - Do not mix raw and cooked meat, they must be in separate containers. Take care not to let the meat juices drip onto other food. If the meat does drip, remove everything and clean thoroughly.

FREEZER COMPARTMENT

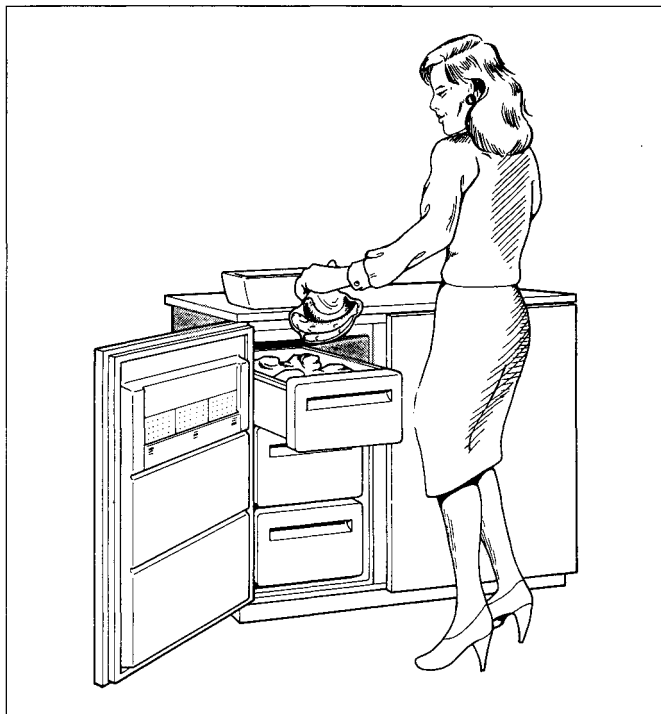

STARTING UP

When starting up the appliance for the first time or after a period of non use, position the thermostat to a medium setting and leave for at least 4 hours before placing the food to be frozen inside.

If you wish to fast-freeze a quantity of fresh food, you must set the switch under the thermostat housing to position «D». Leave it on this position for 24 hours before placing in the food and set it back to position «N» after further 24 hours.

If the switch is already on position «D» (see «Important» at page 8) no further adjustment is required.

The products for freezing should be placed in the upper drawer and then transferred to the lower drawers so that the compartment is left free for the next freezing operation.

The maximum freezing capacity is 4 kg/24h. Never exceed the quantity indicated in one freezing batch.

SOME USEFUL HINTS FOR FREEZING

— The fresh foods to be frozen must be fresh and of the best quality.

— The size of each pack should be small enough to ensure that it is used in one go. Small packs freeze more quickly and uniformly, and give better results.

— Frozen food, once thawed, must not be refrozen. Lean food keeps better and longer than fatty food, salt reduces the storage time.

— Wrap the food in polythene or aluminium freezing bags or foil, so that they adhere to the food and provide an airtight seal. Stick a label on each pack showing the contents and date of freezing. This makes it easy to check storage times. The same information can be copied onto the record cards in the door.

— Never place hot food, bottles or cans of fizzy drink in the freezer as they may explode. Containers with a lid must not be filled to the brim.

— Do not open the door or place extra fresh food in the freezer next to food which is already frozen as this could cause the temperature of the frozen food to rise and its quality and storage life to reduce.

FREEZER COMPARTMENT

STORING READY-

FROZEN FOOD

Storing ready-frozen foods is quite straightforward. The packs can be placed beside each other or on top of each other.

You are strongly advised to place ready-frozen food in the compartment as quickly as possible after purchase and we therefore recommend that you buy them last. Also ensure that the external packaging is intact.

Packaging which is swollen or has traces of refrozen water droplets on the pack could indicate that the product has not been kept at a suitable temperature and that it may have lost its original quality. Partially thawed food must not be refrozen, it must be consumed within 24 hours. Never exceed the storage times indicated.

Do not open the freezer door too often and do not leave open longer than necessary.

IMPORTANT

Do not consume ice-lollies which have just come out of the freezer. Their extremely low temperature can cause frost burns.

CAUTION

In the event of a power cut, the food in the freezer will not be affected if the power cut is short and if the freezer is full. Do not open the door. Should the food begin to thaw, it must be consumed quickly and must not be re-frozen.

THAWING

Food can be thawed in a number of ways, depending on the type of food and the size of the packs.

Meat, fish and fruit should be thawed in the refrigeration compartment and small pieces of meat or poultry can even be cooked while still frozen, but you must ensure that it is thoroughly cooked through.

Vegetables should be directly immersed in boiling water; ready-cooked dishes can be placed directly in the oven in their aluminium wrapping.

A microwave oven is particularly suitable for thawing any type of frozen or deep-frozen food: follow the oven instructions, particularly regarding the placement of aluminium wrapping in the oven.

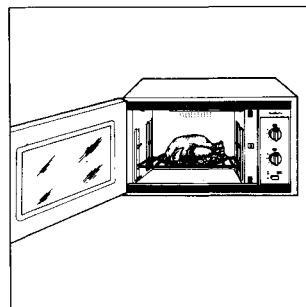

MAKING ICE CUBES

The appliance is provided with a plastic ice cube tray.

Fill the tray 3/4 full to allow the ice to expand and place in one of the freezer drawers.

To turn out the ice cubes, simply give the tray a slight twist to release the cubes.

DEFROSTING

REFRIGERATOR

The refrigerator automatically defrosts every time the compressor stops. The water is discharged, via the pipe, into a tray located at the back of the appliance above the compressor, where it evaporates.

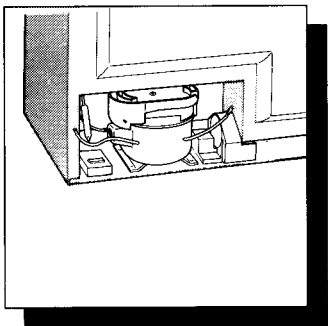

IMPORTANT

To avoid defrost water overflowing into the fridge, periodically clean the water discharge hole in the centre of the V shaped drip collector at the back of the refrigerator compartment behind the fruit and vegetable drawer. Use a flexible device (such as a drinking straw, which is ideal) to facilitate the drainage operation.

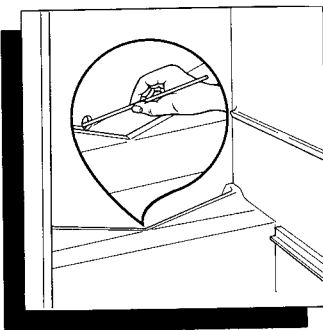

FREEZER

When the frost has reached a thickness of up to 4mm, it can be removed using the ice scraper provided with the appliance. During this operation it is not necessary to disconnect the appliance from the mains and remove the food. Never use metal tools for this operation.

For complete defrosting (once or twice a year) proceed as follows:

- turn the thermostat dial to the «stop» position (●) or disconnect the appliance from the mains.
- Remove any food from inside the freezer and fridge, wrap it in several sheets of newspaper and store in a cool place.
- Leave the door open and insert the ice scraper under the channel in the centre of the lower part of the appliance, place a low-sided container beneath the scraper to collect the water.
- Clean and dry thoroughly.
- Replace the scraper in one of the drawers.
- Reconnect the appliance to the mains or reset the thermostat to a functioning position.

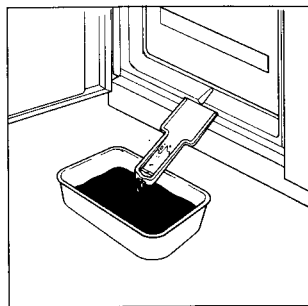

MAINTENANCE

Before all operations, disconnect the appliance from the mains.

INTERNAL CLEANING

Clean the inside and accessories with warm water and sodium bicarbonate (one tablespoon in 4 litres of water). Rinse and dry thoroughly.

The freezer drawers can be easily removed for more thorough cleaning. Pull out fully and lift, unhooking them from the catches.

For repositioning lift the drawers, insert under the catches and slide in.

CLEANING OF THE CONDENSER/FAN

It will be necessary periodically to clean the cooling fan and condenser. If a build up of dust and fluff is allowed around these items it could reduce the operating efficiency of your appliance.

To gain access to these items please follow the instructions.

Isolate from the mains electricity

Pull the appliance out so as to expose the rear

The condenser (black pipe work on right hand base) and fan should be cleaned with soft brush or vacuum cleaner.

EXTERNAL CLEANING

Wash the unit with warm soapy water. Do not use abrasive products.

PERIODS OF NON-USE

When the appliance is not in use, disconnect from the mains, empty, defrost and clean, leaving the doors ajar to prevent unpleasant smells.

REPLACING THE BULB

The bulb can easily be removed via the aperture in the light diffuser.

Use a bulb of the same type (maximum power 10W).

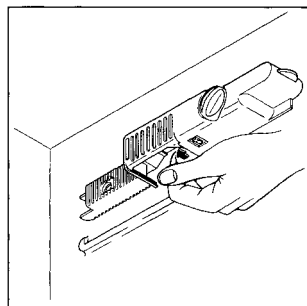

TEMPERATURE GUIDE

The temperature guide will operate correctly up to temperatures of 28°C (80 F). If the guide is exposed to temperatures over 28°C the guide will appear black. The guide will return to normal at lower temperatures and this will not permanently affect operation of the guide.

WHAT TO DO IF THE APPLIANCE DOES NOT WORK

Before calling the Zanussi Service Force, check the following points:

THE APPLIANCE DOES NOT WORK

Check that there is power at the socket. Ensure that there is not a power cut by checking the lights in the house. Check that the thermostat dial is in the correct position.

VIBRATION OR ABNORMAL NOISES

The liquid refrigerant sometimes causes a faint bubbling sound. This is quite normal in an appliance of this type.

TRACES OF WATER ON THE BOTTOM OF THE REFRIGERATION COMPARTMENT

Check that defrosting water discharge hole is not blocked.

THE LIGHT DOES NOT COME ON

Check if the bulb is fitted correctly. Replace if it has blown.

FRIDGE DOES NOT DEFROST

Check that the thermostat setting is not too high (see page 8).

THE TEMPERATURE GUIDE SHOWS TOO WARM

See instructions on page 9.

If, after the above checks there is still a fault, call your nearest Zanussi Service Force Centre, the details of which you can find in your local telephone directory under «Z». Please make sure you give the model and serial number of the appliance. This information can be found on the rating plate inside the refrigerator compartment on the left side behind the vegetable drawer, or on the guarantee certificate.

Original spare parts can be purchased from Zanussi Service Force Centres.

In-guarantee customers should ensure that the above checks have been made as the engineer will make a charge if the fault is not a mechanical or electrical breakdown.

Please note that proof of purchase is required for any in-guarantee service calls.

For advice or assistance, contact Zanussi Customer Care Department on 0635 521313, or write to:
Zanussi Ltd, Zanussi House, Hambridge Road, Newbury, Berkshire, RG14 5EP.

For service, please contact your local Service Force Centre. Refer to your Service Force leaflet supplied with the appliance.

How to find the telephone number of your

Zanussi Service Force

listed in this leaflet

Zanussi Service areas are allocated by postcodes which are listed in alphabetical order for easy reference.

1. Look for the two letters of your address postcode in the far left 'Postcode' column.
2. Match up the number of your postcode against the number listed in the 'Postcode Numbers' column.
3. Look across the column to the Service Force Key Number for your area. Turn to the last page of this directory for the address and telephone number to contact for service which is listed against your key number.

If you are unsure of your postcode, the main towns and cities are listed in alphabetical order for easy reference.

Additionally, your local Zanussi Service Force Centre telephone number is listed under 'Z' in your telephone directory.

The Customer Care Department at Zanussi House, Hambridge Road, Newbury, RG14 5EP, Tel: 0635 521313, will be happy to help you with any queries or difficulties.



Post-code Letter	Town	Post-code Number	Service Force Key Number	Post-code Letter	Town	Post-code Number	Service Force Key Number
AB	Aberdeen	1-5	1	DE	Derby	11-12	18
AL	St Albans	1-10	2	DG	Dumfries	1-7, 10-12	34
A	Brecon	45	3	DG		13-14	35
BA	Bath	1-5, 11-15	4	DG		8-9	36
BA		7-10,20-22	5	DH	Durham	1-9	37
BA		6,16	6	DL	Darlington	1-17	37
BB	Blackburn	1-12	7	DN	Doncaster	1-7, 10-12, 22	33
BD	Bradford	1-23	8	DN		14	38
BD		24	7	DN	Doncaster	8-9, 15-21, 31-40	39
BH	Bournemouth	1-18, 21-25	9	SUB POSTCODE DIVISION			
BH		19-20	10	DN	Gainsborough		
BL	Bury	0-9	11		South	21-1, 21-2, 21-5	40
BN	Brighton	1-9, 11-15,	12	DN	Gainsborough		
BN		20-27	12		North	21-3, 21-4	39
BN		16-18	13	DT	Dorchester	1-6, 10-11	10
BR	Bromley	1-8	14	DT		6-9	5
BS	Bristol	1-28, 98-99	15	SUB POSTCODE DIVISION			
BT	Belfast	1-82	16	DT	Bridport East	6-3, 6-4	10
B	Birmingham	1-21, 25-33,	17	DT	Bridport West	6-5, 6-6	5
B		38, 40, 45, 47-48,	17	DY	Dudley	1-6, 8-9	17
B		60-71, 80, 97-98	17	DY		7, 10-14	41
B	Birmingham	23-24, 34-37,	18	EC	London	All EC Codes	28
B		42-44, 46, 72-	18	EH	Edinburgh	1-42, 52-54	42
B		79	18	EH		43-46	35
B	Birmingham	49-50,	19	EH	Edinburgh	47-49, 51, 55	43
B		96	19	EN	Enfield	1-11	28
B	Birmingham	95	20	EX	Exeter	1-17, 20	45
CA	Carlisle	1-16, 18-28	21	EX		18-23, 31-39	46
CA		17	7	E	London	All East Codes	28
CB	Cambridge	1-8	22	FK	Falkirk	1-4	43
CB		9-11	23	FK		10-14, 18-19	32
CF	Cardiff	1-8, 31-48	3	FK	Falkirk	5-9, 15-17	47
CH	Chester	1-4	24	FK		20-21	31
CH		5-7	25	FY	Fleetwood	0-8	7
CH		8	26	GCI	Guernsey		48
CM	Chelmsford	0-6, 8-9, 11-15	27	GL	Gloucester	1-8, 10-19,	49
CM		7	23	GL		50-56	49
CM	Chelmsford	16-24	28	GL		9	15
CO	Colchester	1-16	23	GL		20	19
CR	Croyden	0, 2-4, 9	29	GU	Guildford	1-24, 26, 34-35	50
CT	Canterbury	1-21	14	GU		25	51
CV	Coventry	1-8, 10-12, 21-23,	20	GU	Guildford	27-33	13
CV		9, 13	18	G	Glasgow	1-5, 11-15, 20-23,	47
CV	Coventry	31-35, 37	20	G		31-34, 40-46, 51-	47
CV		36	19	G	Glasgow	53, 58, 60-69, 73,	47
CW	Crewe	1-12	30	G		76-78, 81-84	47
DA	Dartford	1-18	14	G	Glasgow	71-72, 74-75	43
DD	Dundee	1-5, 7-11	31				
DD		6	32				
DE	Derby	1-7, 13-15, 55	33				

Post-code Letter	Town	Post-code Number	Service Force Key Number	Post-code Letter	Town	Post-code Number	Service Force Key Number
HA	Harrow	0-9	52	L	Liverpool	1-49, 60-70	24
HD	Huddersfield	1-8	8	ME	Medway	1-20, 99	14
HG	Harrogate	1-5	8	MK	Milton Keynes	1-17, 19, 40-46	22
HP	Hemel	1-3	2	MK		18	65
HP	Hempstead	4-23	53	ML	Motherwell	1-12	43
HR	Hereford	1-2, 4, 6-9	49	M	Manchester	1-35, 60	11
HR		3, 5	54	NE	Newcastle -on-Tyne	1-49, 61-70, 88	66
HU	Hull	1-20, 55	38	NE		98-99	66
HX	Halifax	1-7	8	NE		71	35
IG	Ilford	1-11	28	NG	Nottingham	1-23, 25	33
IOM	Isle of Man		55	NG		24	40
IP	Ipswich	1-15, 30-31	56	NG	Nottingham	31-34	64
IP		16-27	57	NN	Northampton	1-7, 11-12	67
IP	Ipswich	28-29, 32-33	22	NN		8-10, 14-18	22
IV	Inverness	1-24, 26, 30-36,	58	NN	Northampton	13	65
IV		40-49, 51-56	58	NP	Newport	1-9, 44	3
IV	Inverness	25, 27-28	59	NR	Norwich	1-35	57
JCI	Jersey		60	NW	London	All NW Codes	52
KA	Kilmarnock	1-26, 28-30	43	N	London	All N Codes	28
KA		27	61	OL	Oldham	1-12, 15-16	11
KT	Kingston-on-Thames	1-23	51	OL		13-14	7
KT		24	50	OX	Oxford	1-17	65
KW	Wick	1-14	59	PA	Paisley	1-4	47
KW		15-17	62	PA		5-19	43
KY	Kirkcaldy	1-16	32	PA	Paisley	20-27, 33, 35, 40-	68
LA	Lancaster	1-23	7	PA		49	68
LD	Llandrindod	1-8	54	PA		28-31	69
LD		3	3	PA	Paisley	32, 34, 36-39, 61	70
LE	Leicester	1-5, 7-8, 11-14,	63	PA		62-78	68
LE		16-17	63	PA	Paisley	80-82, 88	71
LE	Leicester	6, 9-10	20	PA		83-87	72
LE		15	64	PE	Peterborough	1-15, 34, 38	64
LL	Llandudno	11-15	25	PE		16-19	22
LL		16-19	26	PE	Peterborough	20-25	40
LL	Llandudno	20-21, 23, 27, 31-	25	PE		30-33, 35-37	57
LL		32, 34-40, 42-47	25	PH	Perth	1-2, 8-9, 10-18	31
LL	Llandudno	22, 24-26, 28-30,	26	PH		3-7	32
LL		33-34, 41, 48-49,	26	PH	Perth	19-26, 30-44	58
LL		51, 78	26	PL	Plymouth	1-21	73
LN	Lincoln	1-6, 8-10	40	PL		22-35	74
LN		7, 11-13	39	PO	Portsmouth	1-22	13
				PO		30-41	75
				PR	Preston	1-9	7
				RG	Reading	1-17, 26	53
				RG		21-25, 27	50
				RG	Reading	28	4
				RH	Redhill	1-3, 6-7, 9-20	12
				RH		4-5	50
				RH	Redhill	8	29
SUB POSTCODE DIVISION							
LN	Lincoln	3-4, 3-5	40				
LN		3-6	39				
LS	Leeds	1-29	8				
LU	Luton	1-6	2				
LU		7	22				

Post-code Letter	Town	Post-code Number	Service Force Key Number	Post-code Letter	Town	Post-code Number	Service Force Key Number
RM	Romford	1-5, 7, 10-18	27	TR	Truro	1-27	74
RM		6, 8-9	28	TS	Stockton-on-		
SA	Swansea	1-20, 31-32	3		Tees	1-29	37
SA		33, 39, 41-44, 61-73	76	TW	Twickenham	1-20	51
SA	Swansea	40, 45-48	77	UB	Uxbridge	1-10	52
SE	London	All SE Codes	29	WA	Warrington	1-5, 8-9, 10-15	11
SG	Stevenage	1-9, 11,15	2	WA		6-7	24
SG		10, 12-14	28	WA	Warrington	16	30
SG	Stevenage	16-19	22	WC	London	All WC Codes	52
SK	Stockport	1-3, 6-12	30	WD	Watford	1-2, 4-7	2
SK		4-5, 13-16	11	WD		3	53
SK	Stockport	17	33	WF	Wakefield	1-17	8
SL	Slough	1-10	53	WN	Wigan	1-5, 7	11
SM	Sutton	1-3, 7	51	WN		6,8	24
SM		4-6	29	WR	Worcester	1-14	19
SN	Swindon	1-8, 11-16	65	WR		15	41
SN		9-10	4	WS	Walsall	1-15	18
SO	Southampton	1, 4, 41 -43, 51	9	WV	Wolverhampton	1-4, 10-14	18
SO		2-3, 5, 21-24, 52	13	WV		5-9, 15-16	41
SO	Southampton	20	4	W	London	All West Codes	52
SP	Salisbury	1-5, 9-11	4	YO	York	1-3, 5, 7-8	8
SP		6	9	YO		4, 6, 11-18, 25	38
SP	Salisbury	7-8	10	YO	York	21-22	37
SR	Sunderland	1-7, 9	66	ZE	Lerwick	1, 3	79
SR		8	37	ZE		2	80
SS	Southend-on-Sea	0-9, 11-17 ,99	27				
ST	Stoke-on-Trent	1-18, 20-21	30				
ST		19	18				
SW	London	All SW Codes Except 2,9,16	52				
SW	London	2, 9, 16	29				
SY	Shrewsbury	1-6, 9-17, 18-22	25				
SY		7, 17-19	54				
SY	Shrewsbury	8	41				
SY		23-25	77				
S	Sheffield	1-19, 30-31, 40-45	33				
S		60-66, 74, 80-81	33				
S	Sheffield	70-73, 75	8				
TA	Taunton	1-11, 21-24	6				
TA		12-20	5				
TD	Selkirk	1-15	35				
TF	Telford	1-8, 10-13	41				
TF		9	30				
TN	Tonbridge	1-2, 4, 8-18, 23-30	14				
TN		3, 5-7, 19-22, 31-40	12				
TQ	Torquay	1-6, 9, 12-13	78				
TQ		7-8	73				
TQ		14	45				

Service Force Key Number	Service Force Address	Telephone Number	Service Force Key Number	Service Force Address	Telephone Number
1	60 Commerce Street, Aberdeen, AB2 1BP or Tel:	0224 583949 0224 582704	41	1 Underhill Street, Bridgnorth, Salop, WV16	0746 763322
2	Unit 4, Riverside Est, Coldharbour Ln, Harpenden	0582 461909	42	38 Buccleuch Street, Dalkeith, Midlothian, EH22	031 663 7758
3	3 Pentwyn Road, Blackwood, Gwent, Sth Wales	0495 223151	43	Block 2 Unit 5, Auchentraith Ind. Est. Rosendale Way, Blantyre	0698 828145
4	31 St Andrews Road, Bemerton, Salisbury, SP2	0722 336072	44	4 Royal Lane, Wiewsley, W- Drayton, UB7	0895 441917
5	31 East Street, Crewkerne, Somerset, TA18	0460 72740	45	91 Exeter Road, Exmouth, Devon, EX8 1QD	0395 263531
6	80 Killigrew Street, Falmouth, Cornwall, TR11	0984 31858	46	3 Bear St, Barnstaple, North Devon, EX32	0271 717774
7	333 Ranglet Road, Walton Summit, Preston, PR5	0772 321200	47	Unit E6C Anniesland Ind. Est. Netherton Rd, Glasgow, Scotland	041 954 5304
8	57 Ingram Road, Holbeck, Leeds, Yorks,	0532 460992		or Tel:	041 954 5349
9	63 Curzon Road, Bournemouth, BH1 4PW	0202 303363	48	Blencathra, Saumarez Lane, Castel, Guernsey	0481 56854
11	Unit 41/42 Clarendon Ct, Winwick Quay, W'ton	0925 50822	49	134 Eastgate Street, Gloucester, GL1 1QT	0452 422488
12	Unit 3, 21/25 Bridge Road, Haywards Heath, RH1	0444 417656	50	Unit 1 Redfields Ind. Pk, Church Crookham, Fleet	0252 851414
13	266 Main Road, Southbourne, Emsworth, PO10 or Tel:	0243 374814 0243 371170	51	127 Walton Road, Molesey, Surrey, KT8 ODT	081 9796366
14	Bridgewood Hse, 8 Laker Road, Rochester, ME1 or Tel:	0634 201441 0689 61444		or Tel:	081 9797952
15	Unit 1, Albert Crescent, Bristol, BS2 0YH	0272 713217	52	Unit 4, Riverside Est, Coldharbour Ln, Harpenden	0582 461909
16	Owenmore Hse, Kilwee Ind. Est., Upper Dunmurry Lane, Belfast	0232 301121	53	Reform Road, Maidenhead, Berkshire	0628 783711
17	66 Birch Rd East, Wyreley Rd Ind. Est, B'ham	021 327 1671	54	Merion House, High Street, Llandrindod Wells	0597 824842
18	Unit 3 Sterling Park, Claymore, Tamworth or Tel:	0827 289800 0827 289822	55	Tromode Wks, Cronkbourne Vill, Douglas, I.O.M.	0624 76066
19	22 Newton Road, Malvern, Worcester, WR141NZ	0684 572915	56	Unit 2b, Elton Park Business Centre, Hadleigh Rd, Ipswich, IP2 0DQ	0473 211713
20	Unit 23/24, Alliance Business PK, Townsend Drv, Nuneaton, CV11	0203 350666	57	75 Grove Road, Norwich, NR1 3RL	0603 629653
21	High Ehsenside, Egremont, Cumbria, CA22	0946 820509	58	Unit 3B3, Smithton Ind. Est. Smithton, Inverness	0463 791822
22	1 Wharf Road, Higham Ferrers, Northants	0933 317727	59	Main Street, Golspie, Sutherland, KW10 6RA	040 833517
23	Unit 18, Fourth Ave, Bluebridge Ind. Est, Halstead, Essex	0787 473982	60	P.O.Box 45, Queens Road, St Helier, Jersey	0534 67001
24	Unit 14, Dock Road, Birkenhead, L41 1JJ	051 639 1287	61	Bruach, Blackwaterfoot, Isle of Arran	077 086 246
25	Plas Fynnon W/house, Middleton Rd, Oswestry	0691 652917	62	Hatson Ind. Estate, Kirkwall, Orkney	0856 5457
26	Easy Launderette, Pantton Hall, Denbigh, Clwyd	074 581 3272	63	30a Scotland Road, Market Harborough, LE16	0858 33229
27	19 Sirdar Rd, Off Brook Rd, Rayleigh, Essex	0268 741171	64	Pinfold Rd, Manning Rd Ind. Est. Bourne, Lincs	0778 422147
28	284 Alma Road, Enfield, EN3	081 805 6825	65	Unit E19, Telford Rd, Launton Ind. Est. Bicester	0869 248598
29	194 Court Road, Eitham, London, SE9 4EN	081 859 3939	66	Unit C1, Bergen Cl, Tyne Tunnel Ind. Estate, North Shields, Tyne & Wear	091 2960166
30	Unit 8, Croft Road, Newcastle under Lyme, Staffs, ST5 0TW	0782 713003	67	53 Sandringham Road, Northampton, NN1	0604 37061
31	3-7 Blackness Street, Dundee, Scotland, DD1 or Tel: or Tel:	0382 642828 0382 455862 0382 826809	68	96 Argyll Street, Dunoon, Argyll, PA23 7NE	0369 2147
32	33a Burnside, Auchtermuchty, Fife, Scotland	0337 28807	69	43 Crosshill Avenue, Camelton, Argyll	0586 52008
33	Unit 63, Storforth Ln Trad. Est. Chesterfield	0246 231790	70	Moss Field Workshop, Moss Field Drive, Oban	0631 664530
34	93 Irish Street, Dumfries, Scotland	0387 69694	71	2 Killweivagh, Gregory, Benbecula, Outer Hebrides	0870 2331
35	2-8 Wood Market, Kelso, Borders, TD5 7AX	0573 24411	72	Churchouse, 16 James St, Stornaway, Isle of Lewis	0851 5555
36	27 Antrim Ave, Stranraer, Dumfries & Galloway	0776 3277	73	5-7 Brunswick Road, Cattedown, Plymouth, PL4	0752 222540
37	8 Cumbie Way, Aycliffe Ind. Est. Newton Aycliffe	0325 300606	74	80 Killigrew Street, Falmouth, Cornwall, TR11	0326 314600
38	Unit 1, Boulevard Unit Fact. Est. Hull, HU3 4AY	0482 223335	75	109-111 Hunnyhill, Newport, Isle of Wight	0983 523062
39	Unit 2, Cromwell Road, Grimsby, DN31 2BN	0472 358760	76	Roch, Haverfordwest, Dyfed	0437 710366
40	Unit 14 Stonefield Park, Clifton Street, Lincoln	0522 532330	77	4 Market Street, Aberaeron, W. Wales, SA46	0545 570254
			78	250-252 Torquay Road, Preston, Paignton	0803 529969
			79	3-4 Carlton Place, Lerwick, Shetland, ZE1	0595 2915
			80	Harisdale, Symbister, Whalasa, Shetland	08066 546

PEACE OF MIND FOR TWELVE MONTHS

ZANUSSI GUARANTEE CONDITIONS

This guarantee is in addition to your statutory and other legal rights which will not be excluded or in any way diminished by the return of this guarantee card.

We, Zanussi Ltd., undertake that if, within twelve months of the date of the purchase, this ZANUSSI appliance or any part thereof is proved to be defective by reason only of faulty workmanship or materials, we will, at our option, repair or replace the same **FREE OF ANY CHARGE** for labour, materials or carriage on condition that:

- * The appliance has been correctly installed and used only on the electricity supply stated on the rating plate.
- * The appliance has been used for normal domestic purposes only, and in accordance with the manufacturer's operating and maintenance instructions.
- * The appliance has not been serviced, maintained, repaired, taken apart or tampered with by any person not authorised by us.
- * The appliance is still in the possession of the original purchaser.

All service work under this guarantee must be undertaken by a Zanussi Service Force Centre.

Any appliance or defective part replaced shall become our property.

EXCLUSIONS

This guarantee does not cover:

- * Damage or calls resulting from transportation, improper use or neglect, the replacement of any light bulbs or removable parts of glass or plastic.
- * Costs incurred for calls to put right machines improperly installed or calls to machines outside the UK and the Republic of Ireland.
- * Appliances found to be in use within a commercial or similar environment, plus those which are the subject to rental agreements.
- * Products of Zanussi manufacture which are NOT marketed by Zanussi Ltd.
- * EEC Countries - The standard guarantee is applicable but subject to the owner's responsibility and cost to ensure the appliance meets the standards set by the country to which the product is taken. The Zanussi company in the country concerned will be pleased to advise further. Sight of your purchase receipt will be required by them.

... OR FIVE YEARS

ZANUSSI 5 YEAR

COVER CONDITIONS

For a once-only payment you can extend your Standard Guarantee to 5 years.

All the conditions and exclusions of the Standard Guarantee apply.

NOTES

1. Products supplied as "seconds", refurbished, damaged, or shop-soiled are not eligible for Zanussi 5 Year Cover.
2. The issue of a cover does NOT by virtue of our having done so, nullify the exclusions.
3. The Engineer will need to check the details of your Cover card and may make a charge for his services if it is not presented to him at the time of his call.
4. The date of purchase, or the date of initial payment (deposit) of the appliance will be deemed the date of commencement of cover.
5. Covers issued are not refundable or transferable.

GUARANTEE RECORD

Appliance purchased from..... on.....

Guarantee card no..... Model no.....

Serial no..... (These details may be taken from your Guarantee Record Card)

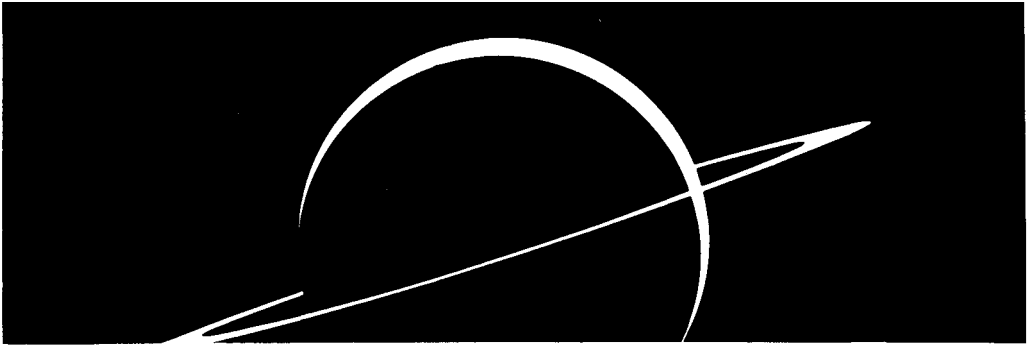

ZANUSSI

The appliance of science

Zanussi Ltd., Zanussi House, Newbury

The information in this manual is correct at time of going to press.
Zanussi reserve the right to alter specifications without notice.